

GENERAC®**Protector® QS
Series****PROTECTOR® QS SERIES
Standby Generators
Liquid-Cooled Gaseous Engine****INCLUDES:**

- Two-Line LCD Multilingual Digital Evolution™ Controller (English/Spanish/French/Portuguese) with external viewing window for easy indication of generator status and breaker position.
- True Power™ Electrical Technology
- Isochronous Electronic Governor
- Sound Attenuated Enclosure
- Closed Coolant Recovery System
- Smart Battery Charger
- UV/Ozone Resistant Hoses
- ±1% Voltage Regulation
- Natural Gas or LP Operation
- 5 Year Limited Warranty
- UL 2200 Listed
- SwRi® listed (NFPA37, clause 4.1.4.1.2) Generator can be installed a minimum 18 in distance from combustible wall*

*Only if located away from doors, windows, and fresh air intakes, and unless otherwise directed by local codes. Please review install guide for more details.

Standby Power Rating

Model RG022 (Aluminum - Bisque) - 22 kW 60 Hz

Model RG027 (Aluminum - Bisque) - 27 kW 60 Hz



*Assembled in the USA using domestic and foreign parts

QUIET-TEST

Meets EPA Emission Regulations
22 & 27 kW are CA/MA emissions compliant
32 & 38 kW not for sale in CA / MA

FEATURES

- **INNOVATIVE DESIGN & PROTOTYPE TESTING** are key components of GENERAC'S success in "IMPROVING POWER BY DESIGN." But it doesn't stop there. Total commitment to component testing, reliability testing, environmental testing, destruction and life testing, plus testing to applicable CSA, NEMA, EGSA, and other standards, allows you to choose GENERAC POWER SYSTEMS with the confidence that these systems will provide superior performance.
- **TEST CRITERIA:**
 - ✓ **PROTOTYPE TESTED** ✓ **NEMA MG1-22 EVALUATION**
 - ✓ **SYSTEM TORSIONAL TESTED** ✓ **MOTOR STARTING ABILITY**
- **MOBILE LINK® CONNECTIVITY:** FREE with all Protector Series Home standby generators, Mobile Link Wi-Fi allows users to monitor generator status from anywhere in the world using a smartphone, tablet, or PC. Easily access information such as the current operating status and maintenance alerts. Users can connect an account to an authorized service dealer for fast, friendly, and proactive service. With Mobile Link, users are taken care of before the next power outage.
- **SOLID-STATE, FREQUENCY COMPENSATED VOLTAGE REGULATION.** This state-of-the-art power maximizing regulation system is standard on all Generac models. It provides optimized FAST RESPONSE to changing load conditions and MAXIMUM MOTOR STARTING CAPABILITY by electronically torque-matching the surge loads to the engine. Digital voltage regulation at ±1%.
- **SINGLE SOURCE SERVICE RESPONSE** from Generac's extensive dealer network provides parts and service know-how for the entire unit, from the engine to the smallest electronic component.
- **GENERAC TRANSFER SWITCHES.** Long life and reliability are synonymous with GENERAC POWER SYSTEMS. One reason for this confidence is the GENERAC product line is offered with its own transfer systems and controls for total system compatibility.

GENERAC®

GENERATOR SPECIFICATIONS

Type	Synchronous
Rotor Insulation Class	H (22 & 27 kW) or F (32 & 38 kW)
Stator Insulation Class	H
Telephone Interference Factor (TIF)	<50
Alternator Output Leads 1-Phase	4 wire
Alternator Output Leads 3-Phase	6 wire
Bearings	Sealed Ball
Coupling	Flexible Disc
Excitation System	Direct

VOLTAGE REGULATION

Type	Electronic
Sensing	Single Phase
Regulation	± 1%

GOVERNOR SPECIFICATIONS

Type	Electronic
Frequency Regulation	Isochronous
Steady State Regulation	± 0.25%

ELECTRICAL SYSTEM

Battery Charge Alternator	12 Volt 30 Amp
Static Battery Charger	2.5 Amp
Recommended Battery (battery not included)	Group 26 (22, 27, 32 & 38 kW)
System Voltage	12 Volts

GENERATOR FEATURES

<p>Revolving field heavy duty generator Directly connected to the engine Operating temperature rise 120 °C above a 40 °C ambient Class H insulation is NEMA rated Class F insulation is NEMA rated All models fully prototyped tested</p>

ENCLOSURE FEATURES

Aluminum weather protective enclosure	Ensures protection against mother nature. Electrostatically applied textured epoxy paint for added durability.
Enclosed critical grade muffler	Quiet, critical grade muffler is mounted inside the unit to prevent injuries.
Small, compact, attractive	Makes for an easy, eye appealing installation.
SAE	Sound attenuated enclosure ensures quiet operation.

ENGINE SPECIFICATIONS: 22, 27, 32 & 38 kW

Make	Generac
Model	In-line
Cylinders	4
Displacement (Liters)	2.4
Bore (in/mm)	3.41 / 86.5
Stroke (in/mm)	3.94 / 100
Compression Ratio	9.5:1
Intake Air System	Naturally Aspirated (22 & 27 kW) or Turbocharged / Aftercooled (32 & 38 kW)
Lifter Type	Hydraulic

ENGINE LUBRICATION SYSTEM

Oil Pump Type	Gear
Oil Filter Type	Full flow spin-on cartridge
Crankcase Capacity (qt/l)	4 / 3.8 (22, 27, 32 & 38 kW)

ENGINE COOLING SYSTEM

Type	Closed
Water Pump	Belt driven
Fan Speed (rpm)	1,980 - 22 & 27 kW 1,500 - 32 & 38 kW
Fan Diameter (in/mm)	18.1 / 459.7 (22 & 27 kW) or 22 / 558.8 (32 & 38 kW)
Fan Mode	Pusher (22 & 27 kW) or Puller (32 & 38 kW)

FUEL SYSTEM

Fuel Type	Natural gas, propane vapor
Carburetor	Down Draft
Secondary Fuel Regulator	Standard
Fuel Shut Off Solenoid	Standard
LP Fuel Pressure	5 – 14 in Water Column
NG Fuel Pressure	5 – 14 in Water Column

22 • 27

GENERATOR OUTPUT VOLTAGE/kW - 60 Hz

		kW LPG	Amp LPG	kW Nat. Gas	Amp Nat. Gas	CB Size (Both)
RG022	120 / 240 V, 1Ø, 1.0 pf	22	92	22	92	100
	120 / 208 V, 3Ø, 0.8 pf	22	76	22	76	80
	120 / 240 V, 3Ø, 0.8 pf	22	66	22	66	80
RG027	120 / 240 V, 1Ø, 1.0 pf	27	113	25	104	125
	120 / 208 V, 3Ø, 0.8 pf	27	94	25	87	100
	120 / 240 V, 3Ø, 0.8 pf	27	81	25	75	90

SURGE CAPACITY IN AMPS

		Voltage Dip @ < .4 pf	
		15%	30%
RG022	120 / 240 V, 1Ø	55	135
	120 / 208 V, 3Ø	40	92
	120 / 240 V, 3Ø	35	80
RG027	120 / 240 V, 1Ø	62	170
	120 / 208 V, 3Ø	70	120
	120 / 240 V, 3Ø	61	103

ENGINE FUEL CONSUMPTION

		Natural Gas		Propane		
		(ft³/hr)	(m³/hr)	(gal/hr)	(ft³/hr)	(l/hr)
RG022	Exercise cycle	42	1.2	0.44	16	1.7
	25% of rated load	100	2.8	1.1	40	4.2
	50% of rated load	190	5.4	2.1	75	7.8
	75% of rated load	255	7.2	2.8	101	10.5
	100% of rated load	316	9	3.4	125	13
RG027	Exercise cycle	42	1.2	0.44	16	1.7
	25% of rated load	108	3.1	1.2	43	4.5
	50% of rated load	197	5.6	2.1	78	8.1
	75% of rated load	287	8.2	3.1	114	11.8
	100% of rated load	359	10.2	3.9	143	14.8

Note: **Fuel pipe must be sized for full load.**

For Btu content, multiply ft³/hr x 2,520 (LP) or ft³/hr x 1,000 (NG)

For megajoule content, multiply m³/hr x 93.15 (LP) or m³/hr x 37.26 (NG)

Refer to "Emissions Data Sheets" for maximum fuel flow for EPA and SCAQMD permitting purposes.

STANDBY RATING: Standby ratings apply to installations served by a reliable utility source. The standby rating is applicable to varying loads for the duration of a power outage. There is no overload capability for this rating. Ratings are in accordance with ISO-3046-1. Design and specifications are subject to change without notice.

ENGINE COOLING

	22 kW	27 kW	
Air flow (inlet air including alternator and combustion air in cfm / cmm)	2,400 / 68	2,400 / 68	
System coolant capacity (gal / liters)	2.5 / 9.5	2.5 / 9.5	
Heat rejection to coolant (BTU per hr / MJ per hr)	99,000 / 104.5	105,000 / 110.8	
Maximum operation air temperature on radiator (°F / °C)	140 / 60		
Maximum ambient temperature (°F / °C)	122 / 50		

COMBUSTION REQUIREMENTS

Flow at rated power (cfm / cmm)	68 / 1.9	68 / 1.9	
---------------------------------	----------	----------	--

SOUND EMISSIONS

Sound output in dB(A) at 23 ft (7 m) with generator in exercise mode*	61	61	
Sound output in dB(A) at 23 ft (7 m) with generator operating at normal load*	70	70	

EXHAUST

Exhaust flow at rated output (cfm / cmm)	165 / 4.7	180 / 5.1	
Exhaust temperature at muffler outlet (°C / °F)	482 / 900	538 / 1,000	

ENGINE PARAMETERS

Rated Synchronous rpm	1,800
-----------------------	-------

POWER ADJUSTMENT FOR AMBIENT CONDITIONS

Temperature Deration	3% for every 10 °C above 25 °C or 1.65% for every 10 °F above 77 °F
Altitude Deration (22 & 27 kW)	1% for every 100 m above 183 m or 3% for every 1,000 ft above 600 ft
Altitude Deration (32 & 38 kW).....	1% for every 100 m above 915 m or 3% for every 1,000 ft above 3,000 ft

CONTROLLER FEATURES

Two-Line Plain Text LCD Display	Simple user interface for ease of operation.
Mode Switch: Auto	Automatic Start on Utility failure. 7 day exerciser.
Off	Stops unit. Power is removed. Control and charger still operate.
Manual	Start with starter control, unit stays on. If utility fails, transfer to load takes place.
Programmable start delay between 10 – 30 seconds	10 sec standard
Engine Start Sequence	Cyclic cranking: 16 sec on, 7 rest (90 sec maximum duration)
Engine Warm-up	5 sec
Engine Cool-Down	1 min
Starter Lock-out	Starter cannot re-engage until 5 sec after engine has stopped.
Smart Battery Charger	Standard
Automatic Voltage Regulation with Over and Under Voltage Protection	Standard
Automatic Low Oil Pressure Shutdown.....	Standard
Overspeed Shutdown.....	Standard, 72 Hz
High Temperature Shutdown	Standard
Overcrank Protection	Standard
Safety Fused	Standard
Failure to Transfer Protection.....	Standard
Low Battery Protection.....	Standard
50 Event Run Log.....	Standard
Future Set Capable Exerciser	Standard
Incorrect Wiring Protection	Standard
Internal Fault Protection.....	Standard
Common External Fault Capability	Standard
Governor Failure Protection	Standard

REMOTE MONITORING

● Ability to view generator status	Monitor generator with a smartphone, tablet, or computer at any time via the Mobile Link application for complete peace of mind.
● Ability to view generator Exercise / Run and Total Hours	Review the generator's complete protection profile for exercise hours and total hours.
● Ability to view generator maintenance information	Provides maintenance information for the specific model generator when scheduled maintenance is due.
● Monthly report with previous month's activity	Detailed monthly reports provide historical generator information.
● Ability to view generator battery information	Built in battery diagnostics displaying current state of the battery.
● Weather information	Provides detailed local ambient weather conditions for generator location.

Model #	Product	Description
G0071690	Mobile Link® 4G LTE Cellular Accessory	Generac's Mobile Link allows you to check the status of your generator from anywhere that you have access to an Internet connection from a PC or with any smart device. You will even be notified when a change in the generator's status occurs via e-mail or text message. Note: Harness Adapter Kit required. Available in the U.S. only.
G006478-0	Kit, Adapter Mobile Link L/C (Required for QT and RG Series)	The Harness Adapter Kit is required to make liquid-cooled units compatible with Mobile Link®.
G005630-1 - 22, 27, 32 & 38 kW	Cold Weather Kit	If the temperature regularly falls below 32 °F (0 °C), install a cold weather kit to maintain optimal battery temperature. Kit consists of battery warmer with thermostat built into the wrap.
G005651-0	Base Plug Kit	Add base plugs to the base of the generator to keep out debris.
G005703-0 - Bisque	Paint Kit	If the generator enclosure is scratched or damaged, it is important to touch-up the paint to protect from future corrosion. The paint kit includes the necessary paint to properly maintain or touch-up a generator enclosure.
G005656-0 - 22 & 27 kW	Scheduled Maintenance Kit	The Liquid-Cooled Scheduled Maintenance Kits offer all the hardware necessary to perform complete maintenance on Generac liquid-cooled generators.
G006664-0	Local Wireless Monitor	Completely wireless and battery powered, Generac's wireless remote monitor provides you with instant status information without ever leaving the house.
G006665-0	Wireless Remote Extension Harness	Recommended for use with the Wireless Remote on units up to 60 kW, required for use on units 70 kW or greater.
G007000-0 (50 Amps) G007006-0 (100 Amps)	Smart Management Module	Smart Management Modules (SMM) optimize the performance of a standby generator. They manage large electrical loads upon startup and load shed to aid in recovery when overloaded. In many cases, SMMs can reduce the overall size and cost of the system.
G007993-0	E-stop toggle switch for residential installs to NEC2017	E-stop allows for immediate fuel shutoff and generator shutdown in the event of an emergency.
G006510-0	E-Stop resettable switch for commercial installs to NEC2020	E-stop allows for immediate fuel shutoff and generator shutdown in the event of an emergency.
G007005-0	Wi-Fi LP Fuel Level Monitor	The Wi-Fi enabled LP fuel level monitor provides constant monitoring of the connected LP fuel tank. Monitoring the LP tank's fuel level is an important step in making sure your generator is ready to run during an unexpected power failure. Status alerts are available through a free application to notify when your LP tank is in need of a refill.
A0000018981	Ultrasonic Cleaner Solution	An ultra-concentrated anti-corrosive cleaning solution engineered to reach the smallest cavities to clean the toughest contaminants. This water based formula is non-toxic, biodegradable, and safe for both metal and plastic surfaces and is superior in rinsability.
A0000019001	All Surface Protectant	All Surface Protectant for vinyl, rubber, and plastics creates a barrier that seals & protects surfaces from water and UV rays while renewing the look of the surface.

22 & 27 kW

Drawing #0K8624-C (1 of 2)

installation layout

NOTES:

- MINIMUM RECOMMENDED CONCRETE PAD SIZE: 1092 (43") WIDE X 1885 (74.2") LONG. REFERENCE INSTALLATION GUIDE SUPPLIED WITH UNIT FOR CONCRETE PAD GUIDELINES.
- ALLOW SUFFICIENT ROOM ON ALL SIDES OF THE GENERATOR FOR MAINTENANCE AND SERVICING. THIS UNIT MUST BE INSTALLED IN ACCORDANCE WITH CURRENT APPLICABLE NFPA 37 AND NFPA 70 STANDARDS AS WELL AS ANY OTHER FEDERAL, STATE, AND LOCAL CODES.
- CONTROL PANEL / CIRCUIT BREAKER INFORMATION:
 - SEE SPECIFICATION SHEET OR OWNERS MANUAL.
 - ACCESSIBLE THROUGH CUSTOMER ACCESS ASSEMBLY DOOR ON REAR OF GENERATOR.
 - REMOVE THE REAR ENCLOSURE COVER PANEL TO ACCESS
- THE STUB-UP AREAS AS FOLLOWS:
 - HIGH VOLTAGE CONNECTION INCLUDING AC LOAD LEAD CONDUIT CONNECTION
 - NEUTRAL CONNECTION, BATTERY CHARGER 120 VOLT AC (0.5 AMP MAX) CONNECTION.
 - LOW VOLTAGE CONNECTION INCLUDING TRANSFER SWITCH CONTROL WIRES.
- CENTER OF GRAVITY AND WEIGHT MAY CHANGE DUE TO UNIT OPTIONS.
6. BOTTOM OF GENERATOR SET MUST BE ENCLOSED TO PREVENT PEST INTRUSION AND RECIRCULATION OF DISCHARGE AIR AND/OR IMPROPER COOLING AIR FLOW.
- REFERENCE OWNERS MANUAL FOR LIFTING WARNINGS.
- MOUNTING BOLTS OR STUDS TO MOUNTING SURFACE SHALL BE 5/8"-11 GRADE 5 (USE STANDARD SAE TORQUE SPECS)
- NEVER ALLOW FREE FLOW OF INTAKE AIR, DISCHARGE AIR AND EXHAUST. SEE SPEC SHEET FOR MINIMUM AIR FLOW AND MAXIMUM RESTRICTION REQUIREMENTS.
- GENERATOR MUST BE INSTALLED SUCH THAT FRESH COOLING AIR IS AVAILABLE AND THAT DISCHARGE AIR FROM RADIATOR IS NOT RECIRCULATED.
- EXHAUST MUFFLER AND FAN BELT ENCLOSED WITHIN GENERATOR ENCLOSURE. REMOVE FRONT PANEL TO ACCESS.

SERVICE ITEM	2.4L
OIL FILL CAP	EITHER SIDE
OIL DIP STICK	RIGHT SIDE
OIL FILTER	RIGHT SIDE
OIL DRAIN HOSE	LEFT SIDE
RADIATOR DRAIN	LEFT SIDE
COOLANT RECOVERY BOTTLE	LEFT SIDE
RADIATOR FILL CAP	ROOF TOP
AIR CLEANER ELEMENT	LEFT SIDE
SPARK PLUGS	LEFT SIDE
MUFFLER	EITHER SIDE
DRIVE BELT	SEE NOTE 11
FAN BELT	SEE NOTE 11
BATTERY	LEFT SIDE

REFERENCE OWNERS MANUAL FOR PERIODIC REPLACEMENT PART LISTINGS.

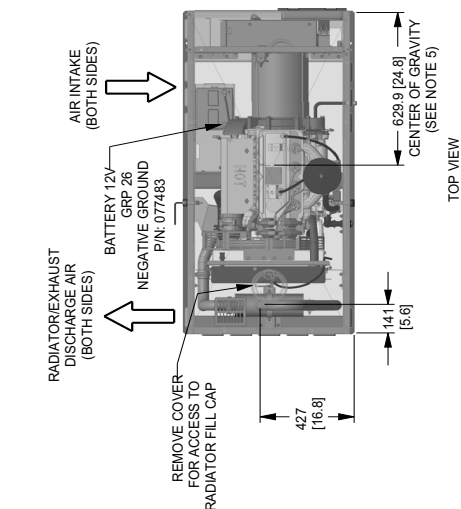

TOP VIEW

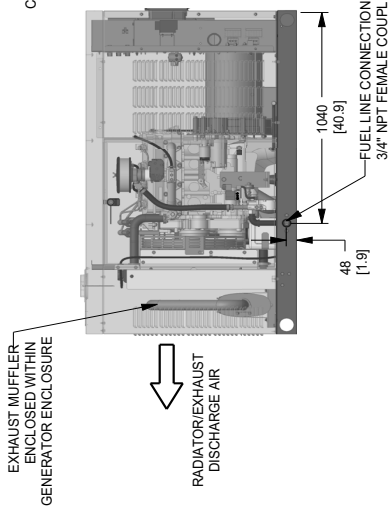

LEFT SIDE VIEW

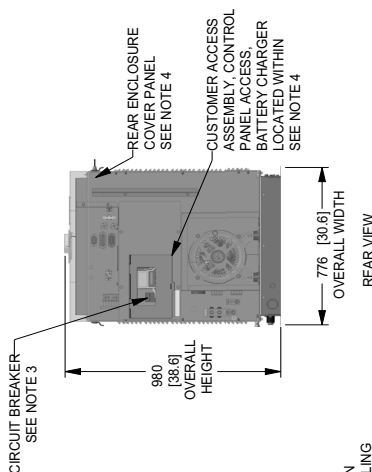

REAR VIEW

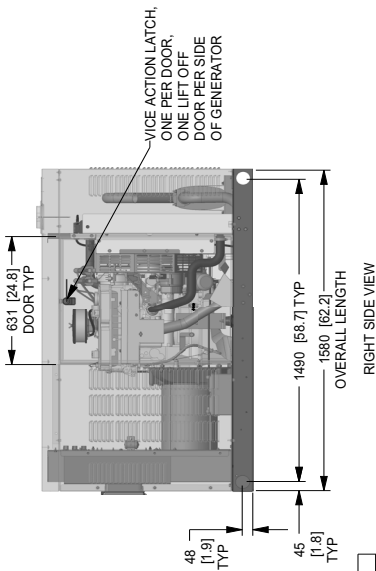

RIGHT SIDE VIEW

ENGINE/KW KVA	ENCLOSURE MATERIAL	WEIGHT DATA	
		WEIGHT GENSET ONLY KG [LBS]	WEIGHT SHIPPING SKID KG [LBS]
2.4L 20KW (60HZ) SINGLE PHASE 22KVA (50HZ)	AL	410.5 [905]	30 [66]
2.4L 27KW (60HZ) SINGLE PHASE 21.6KVA (50HZ)	AL	426 [940]	30 [66]

DIMENSIONS: MM [INCH]

22 & 27 kW

installation layout

Drawing #OK8624-C (2 of 2)

*NOTE - STUB-UP AREA FOR HIGH AND LOW VOLTAGE CONNECTIONS, CIRCUIT BREAKER, NEUTRAL, AND CUSTOMER CONNECTION OPENING.

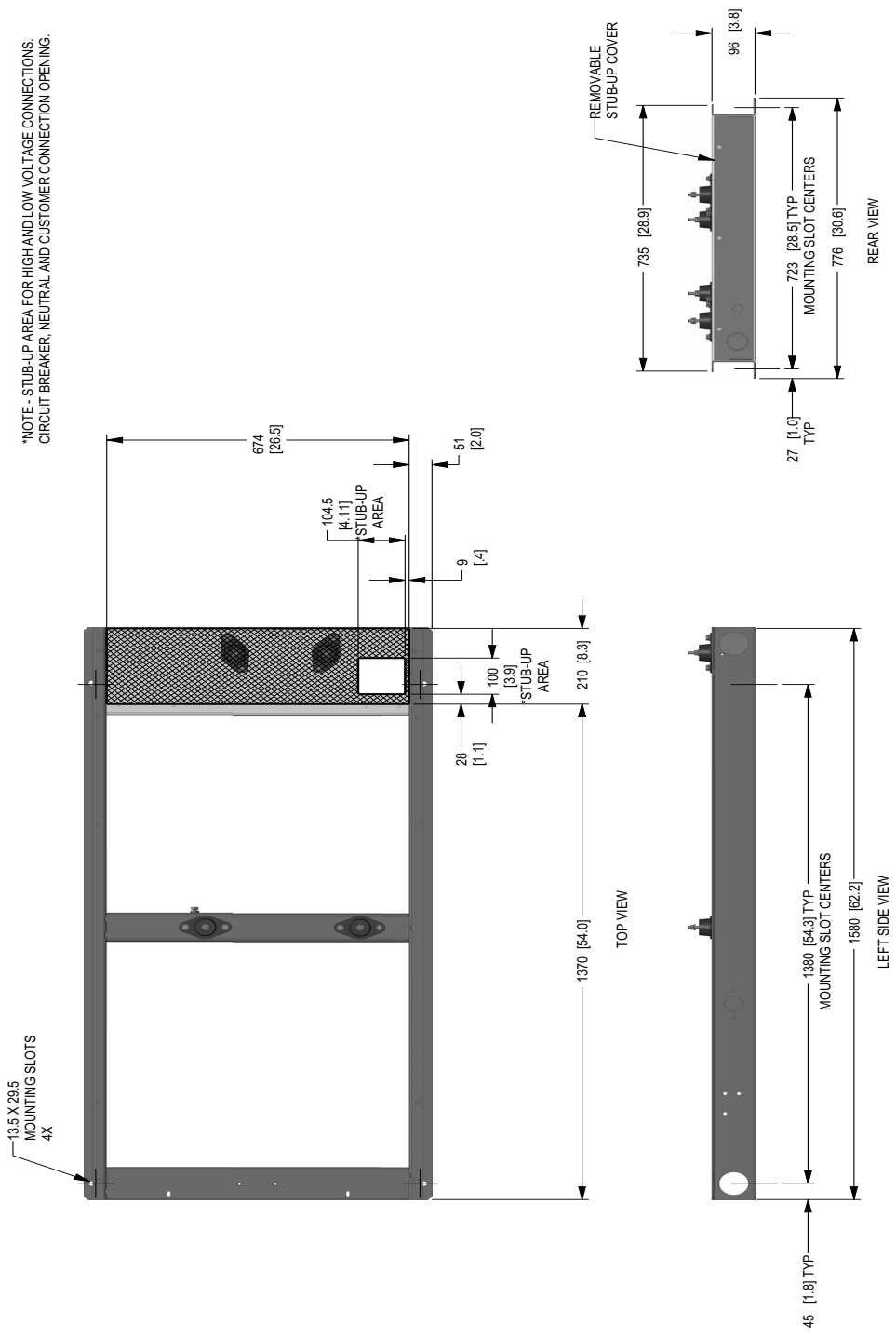

DIMENSIONS: MM [INCH]